

Model 6236

SOFT SERVE FREEZER

Application

Single flavor, High Volume Countertop Gravity or Pump feed soft serve machine for ice cream, frozen yogurt, custards and sorbet.

Freezing Cylinder

One × 3.4 quarts

Mix Hopper

16 quarts with standard hopper agitation
Separate hopper refrigeration maintains mix temperature below 40°F.

Mix Low Indicator

When mix level is low, the Mix Low light turns “ON” to alert operator to add mix. Compressor shut down setting prevents freeze up or machine damage.

Standby

The standby feature maintains safe product temperature in the mix hoppers and freezing cylinders below 40° during long no-use periods.

Microprocessor Controls

Automatically regulates refrigeration and maintains consistent product quality by controlling product temperature and viscosity. Can be set to go into standby automatically.

Counter

Records number of dispenses per day and total number of dispenses.

Temperature Display

Displays hopper and cylinder temperature.

Output

150 servings per hour.
(Serving size 4 ounces by weight)

Safety Protections

- Low temperature sensors and motor overload circuit switch will protect the cylinder from over freezing.
- High pressure switch prevents compressor overheat
- Thermal overload protects from motor overheat



Flexible Blade Beater
Higher capacity, higher overrun



AUTHORIZED DEALER
H&M Company USA, Inc.
700 Aldo Ave. • Santa Clara, CA 95054
sales@hmcompanyusa.com
www.HMCompanyUSA.com

U.S. IMPORTER:
Spaceman International USA, Inc.
805-927-2257
info@spacemanusa.com
www.spacemanusa.com

MODEL 6236

MODEL 6236

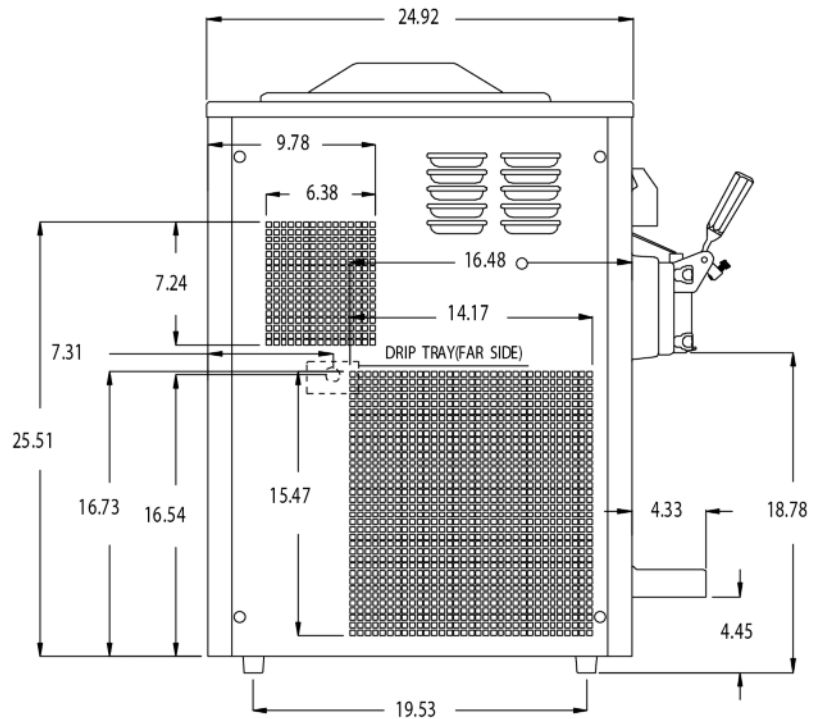
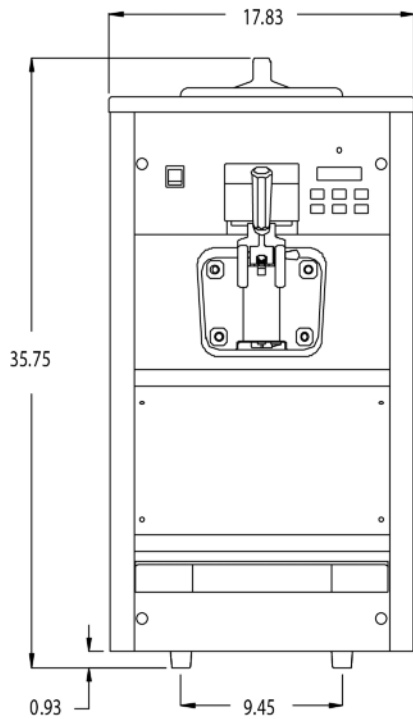

Specifications

Weight	Pounds
Net	364
Shipping	408

Packaging Volume	32 CBF
-------------------------	--------

Dimensions	Net - inches	Shipping - inches
Width	18	25.6
Depth	25	30.7
Height	35.8	45.7

Electrical	Fuse Size	Minimum Circuit Amp	Poles (P) Wires(W)
208-230/60/1	30	24	3P/3W
208-230/60/3	30	18	/4W

This unit may be manufactured in other electrical characteristics. Refer to the local Distributor for availability. (For exact electrical information, always refer to the data label of the unit.)

Note

Continuing research results in steady improvements, therefore, these specifications are subject to change without notice.

Electrical

One dedicated electrical connection is required. Unit shall be cord connected or permanently connected. Consult your local Spaceman distributor for receptacle specifications.

Beater Motor

One @ 1.5 HP for 1 Phase
One @ 1.0 HP for 3 Phase

Refrigeration System

Main refrigeration:
One compressors: @ 6500 BTU/hr. R404a

Separate hopper refrigeration (S.H.R.):

One compressor: 480 BTU/hr. R134a

Air Cooled

Minimum clearance of 6" on both sides is required to achieve optimum performance. The rear of the unit may be placed against a wall.

Options

- Top Air Discharge Chute (air cooled only).
- Water Cooled.

Spaceman Factory in China is:
ISO 9001: 2008 Registered Firm

Spaceman machines are sold by Distributors in specific territories. Contact the Distributor responsible for your Territory.



For Sales & Service Contact:
H&M Company USA, Inc. (408) 899-9068 | sales@hmcompanyusa.com